

ATHENA



R19 ROBOT SYSTEM

User manual

System Components:

A basic R19 robot system comprises the following: -

- 1 R19 Robot arm
fitted with any options:
 - Electric or pneumatic gripper
 - Quickstop sensor
 - Tool changer
- 1 Track
- 1 Controller K11R
- 1 Teach box
- 1 Cable 9-way D-type each end (M-M) - K11R to teach box
- 1 Motor cable - K11R MS connector to robot 25-way D-type
- 1 Sensor and encoder cable - 25-way each end (M-F)
- 1 Cable, D-type 25-way male to 9-way female - K11R to PC RS232
- 1 Power cable to K11R
- 1 Pack of CONNECTORS:
 - 1 output connector (unless already used for gripper)
 - 1 input connector
 - 1 stop circuit jack
- 1 Disk with software and manuals.
- 1 optional USB/serial adaptor
- 1 optional gripper pneumatics kit
- 1 optional Quickstop pneumatics kit

1. INTRODUCTION

The R19, ATHENA is a robot arm of the cylindrical format i.e. its workspace is cylindrical. It is highly suitable for bench top handling and is more accurate than other formats. Athena has a nominal reach of 550mm. Athena is driven by stepping motors controlled by intelligent micro-stepping MOS power drives with incremental encoder feedback. A choice of grippers is available: pneumatic or electric. If fitted the pneumatic gripper is operated by compressed air from 5 to 7 bar. This may be supplied by a compressor supplied with the kit, or from another air supply.

The R19 robot system comprises 3 main units:- the robot, the controller, the computer or terminal. The computer is used to program the controller. Once programmed the controller will run the robot independently without the need for the terminal or computer but it is a good idea to have a low cost terminal connected while the robot is in use.

OVERVIEW

All movement of the robot is controlled by the controller. As the controller may be both reading sensors and signals from and controlling associated equipment it follows that all decisions about robot activity are usually made by the controller which is capable of running without any host computer. The function of the computer is to (a) program the controller, (b) to copy (back up) the contents of controller RAM to disk and optionally (c) to perform a supervisory role sending commands to the controller through the RS232 interface. The function of a terminal is to display information or questions and for the operator to enter answers or commands (e.g. part type selection).

To program the controller with a computer you need to run the utility ROBWIN.EXE. When ROBWIN is executed it immediately opens a communications window. Once communication is established all your commands go to the controller not to the computer you are typing on. Programming the controller involves programming the robot and the interaction with other equipment. The robot and interfacing are programmed using ROBOFORTH II and FORTH. There are two HTML manuals, ROBOFORTH covering robot programming and the system manual, which describes the controller and interfacing. You can use the dynamic links to see connected concepts. There is also a glossary on disk, which gives a brief description of every command. Some commands are used only by ROBWIN or are not very useful and these are in the glossary but not in the ROBOFORTH manual. In particular you should start off with the "getting started" manual which is a pdf.

All FORTH and ROBOFORTH commands are in UPPER CASE (press caps lock). You can add commands written in lower case but these would be different commands from those spelled in upper case.

2. IMPORTANT DOS AND DON'TS

- (1) DON'T ever disconnect *or connect* the robot while the controller is switched on. This will result in damage to the electronics and the connectors themselves. Warranty claims will not be accepted for damage resulting from this.
- (2) DO be very careful not to "crash" i.e. drive any joint against a solid object so that it stalls. Depending on the speed damage may result. At lower speeds the motors generate higher torques so can do more damage. DON'T drive the waist against the stop.
- (3) For the above reason DON'T use CALIBRATE unless you are sure the robot will not crash into something in the workspace.
- (4) DON'T use CALIBRATE unless you are sure the robot is in the valid position for calibration including taking into account any complex end effector fitted.
- (5) DO have your hand poised over the emergency stop button whenever testing a program. Remember that because of its geometry the arm may describe wide arcs from far apart points, and may collide with objects within its reach.
- (6) DO make a back-up of the computer disk supplied as soon as possible.
- (7) DO take appropriate measures to assess the risks and protect personnel from injury (see next section)

SAFETY IS YOUR RESPONSIBILITY

Risks

Because stepping motors raise more torque at low speeds a substantial low speed force can be brought to bear especially on fingers, which may become trapped under or between axes. Robot end effectors typically have sharp edges or fingers made of thin metal, which can cause injury at the low speed high forces or at the higher speeds.

The biggest risk comes from the element of surprise. If the system is active and receives a command from a supervising scheduler or a signal from an associated machine the robot will appear to move unpredictably. A human being caught in the way can receive injury.

However, because the robot is stepper motor driven, once stalled the system raises an error and does not attempt further motion.

Safety measures

- Where possible a robot system should be guarded. Any gate in the guarding can be fitted with a switch, which is connected to the controller stop circuit.
- If physical guards cannot be provided then light curtains are easily connected to the robot controller
- Where guarding is not appropriate and bench-top robots work closely with human workers interlocks should be provided. For example if the user has access to the workspace then he/she should be required to press a switch or keyboard key after clearing the area.
- A good rule is that the robot should not be allowed to move outside an area designated by the edge of the bench on which it is mounted.
- As an additional precaution the working area should be marked out with painted lines or black/yellow striped tape.
- Statistically the highest incidence of contention between human and robot is when both are accessing the same object. End effectors often have sharp edges, which can cause injury. This hazard can be minimized by fitting a collision sensor.
- At the end of this manual you will find a form with which to do your own risk assessment of the robot *in your application*. There are two concepts to consider: hazard, which is the robot or robot fingers or the product etc. and risk, which is the probability of someone being harmed by the hazard. The form enables you to identify the hazards, the risks and ways of minimizing the risks. After completing the form and carrying out any safety measures that the form has helped you identify, do the assessment all over again.

3. SETTING UP

Assembly:

The robot is packed with the extend axis (with hand) separated from the lift axis (with waist). They are connected with a permanent cable hose.

1. Set the robot up in the desired location.
2. Remove all from the case. Place the waist unit on a level surface with the lift axis vertical.
3. You can see where the extend axis carriage plate mounts to the lift axis carriage plate with 4 holes. Offer the extend axis up to the lift axis with the slot and the carriage plate uppermost.
4. Line up the 4 holes and insert the 4 screws provided. Make sure the steel cones are between the axes. Use nuts and washers according to this diagram.

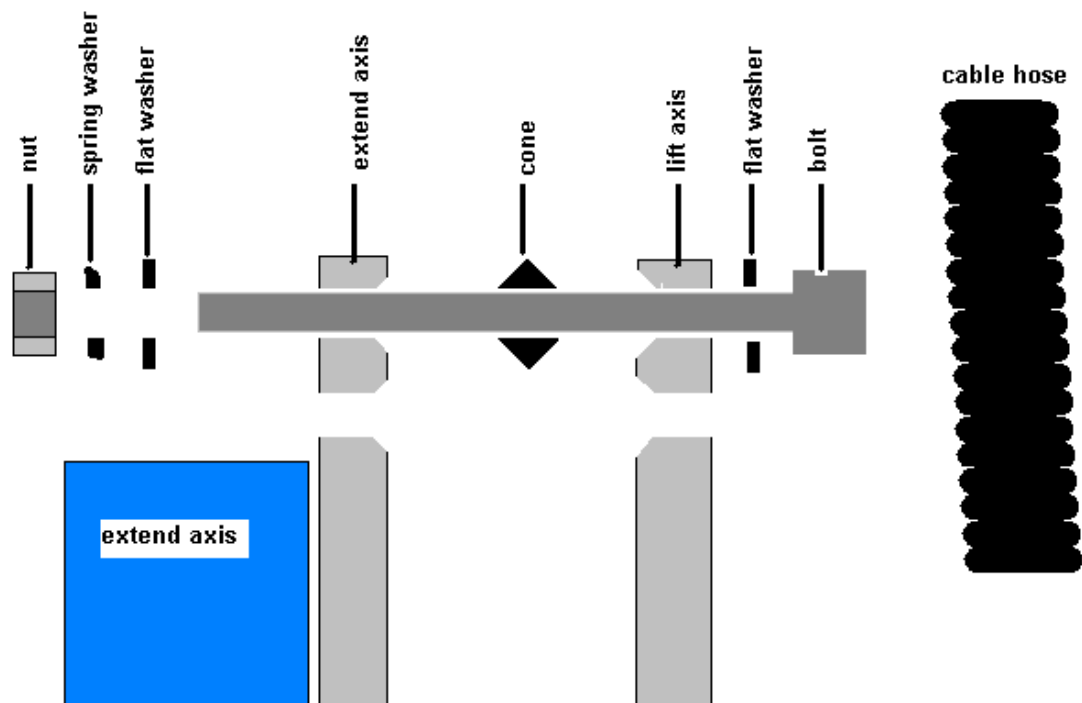

5. Tighten the four screws. An Allen key (wrench) and 8mm spanner (wrench) are provided.
6. Make sure the robot is bolted down so it can't slip or fall over. Rotate the waist by hand to feel out the limits of rotation and set the waist in it's mid position

Assembly to track

7. Mount the robot on to the track carriage plate. Orient it so that the connector plate of the robot should be nearest to the drive box of the track. Use the four large bolts provided with flat washers under the heads. Tighten using the Allen key (wrench) provided.
8. Connect the two cables which emerge from the track on to the connectors at the read of the robot arm.

Setting up for use

Connect up all cables - their positions should be self-evident. Cables to the robot connect to the rear of the controller.

There are 5 basic cables:

Motor power – the metalized cable from rear of controller to robot base, 26wMS to 26wMS.

When there is a track this cable goes to the connector plate of the track.

Sensor cable – from rear of controller to robot base (25wD male to 25wD female)

When there is a track this cable is doubled i.e. two cables end to end for extra length. Connect it to the 25-w D connector on the end of the track.

Gripper cable (if supplied) - from rear of controller to gripper valve (9wD to DIN)

Serial cable – from front of controller to computer (usually 25wD male to 9wD fem)

Teach pad cable – from front of controller to teach pad (9wD to 9wD male to male).

There is also a **Stop Jack** for connecting an external stop circuit. Even if there is no external stop circuit the jackplug must be plugged in at the rear of the controller. The plug has a shorting link, which is removed when connecting an external circuit.

The serial (RS232 null modem) cable from a computer to the controller should plug into the 25-way D connector on the front of the controller. The other end (usually 9wD) connects to the rear COM1 serial connector of the computer. If COM1 is already in use you can use any COM port or the USB serial adaptor (usually COM7). The serial speed is 19200 Baud, 8 bits, 1 stop bit.

DOS utilities only work with COM1.

Pneumatic connections

Connect the air line by pushing it into the push-fit connectors on the air valve and two from the valve to the rear of the robot. If there is no compressor supplied then connect the shop air supply to the air valve. The air supply must have a bowl filter and a pressure regulator.

Pneumatic gripper

If a pneumatic gripper is fitted the robot will have two airlines fitted through it, emerging on the forearm on two push-fit connectors. Two external lines loop to the gripper. The control valve is usually external. The valve is controlled from port PA bit 0.

The pneumatic gripper is optionally fitted with a sensor to detect if the gripper is holding an object or has closed completely without an object. This sensor is usually connected to input port PB bit 7.

Electric gripper

If the electric gripper is fitted this is wired through the robot and requires no installation by the customer. The gripper is controlled from port PA bit 0. Therefore you can not use this output line for any other purpose.

Quick-stop sensor

This works with compressed air, requiring a separate airline and its own pressure regulator and another airline emerging from the forearm as well as an electrical cable and connector. The device is held rigid by pressure and if the pressure is broken by force on the sensor the stop circuit is broken and the robot stops. The force required to 'break' the sensor is determined by the air pressure.

For initial setting up you may prefer to leave this pressure off. Replace the electrical connector from the quickstop to forearm with the dummy supplied.

Connect as per the diagram below. Short tubes may be provided for test but you may need new air tubes when you have installed the pneumatics.

When you are ready to use the sensor connect the airline, turn on pressure and manipulate the end effector until the sensor locks. Then replace the electrical connector.

To test the sensor enter

STOPCHECK <enter>

The result when the sensor is locked will be OK

Enter STOPCHECK but before you press enter force the sensor open then press <enter>.

The result will be 'STOP BUTTON PRESSED'.

Don't do this test until you have performed the initial setup in sections 3 and 6.

Pneumatic Gripper connections

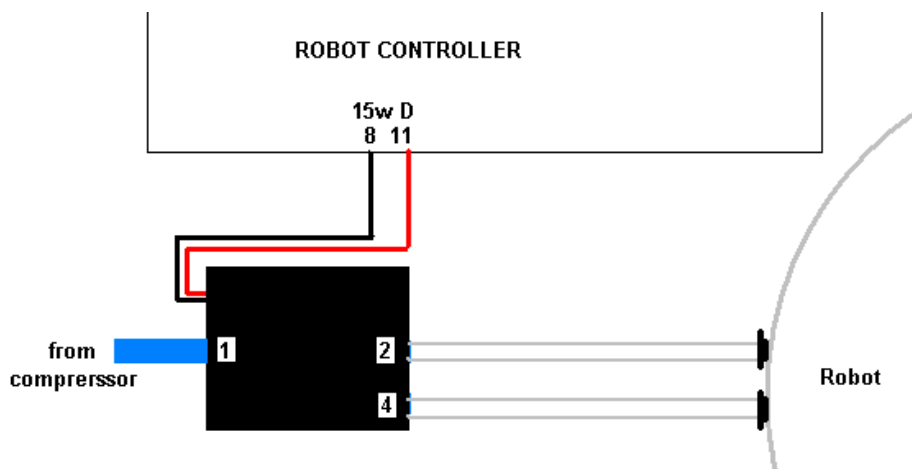

Quick-stop pneumatic connections:

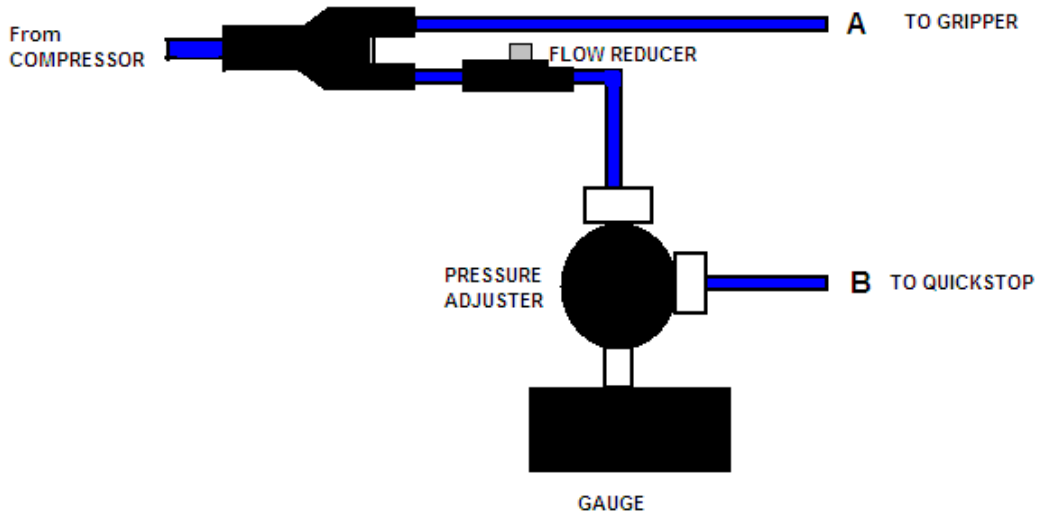

Vacuum pick-up connections:

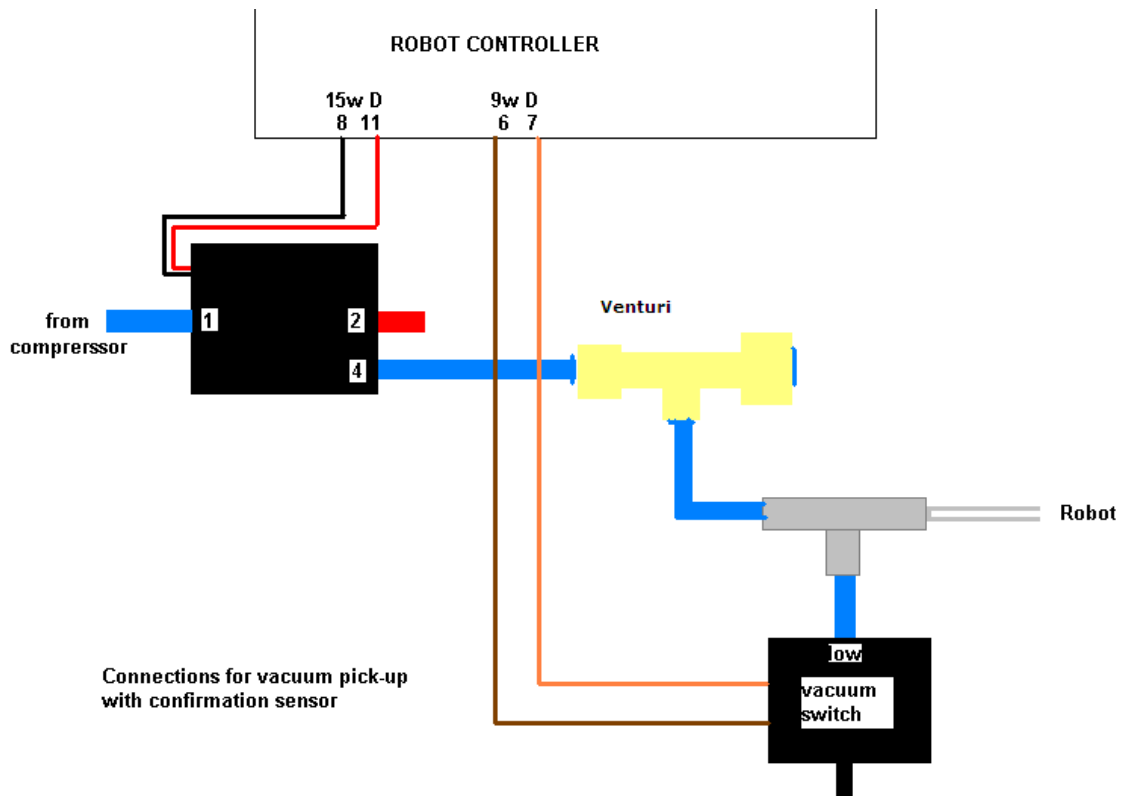

4. COMPUTER

Note: Commands to computer or controller are in the form of a string of characters followed by the enter key. In all my examples of dialog between man and machine I will underline text typed in by the user. I won't keep mentioning the need for the enter key. A machine response will be in upper case but not underlined. My comments will be in lower case.

Before switching on the controller switch on the terminal or computer and proceed as follows:-

WINDOWS

1. Create a directory (folder) ROBOT on C: drive
2. Copy all the files to your ROBOT directory
3. If you have a **USB-serial converter** connect that and insert the converter CD when prompted.
4. When it is installed check via control panel, system, hardware, device manager. Scroll down to ports and check what port COM number has been allocated to the converted.
5. Find robwin63.exe and make a shortcut if you wish.
6. Simply run robwin.exe
7. ROBWIN defaults to COM1. If you need to change the port number click Comm, configure. Baud rate should be 19200
8. Click Settings, Open file then enter:

c:\robot\r17.cfg

In any event make sure that in settings, configuration, that bank memory is checked. You are now ready to use ROBWIN

DOS

If you are using DOS connect the robot to the COM1 port then insert the disk and enter EZCOM, a batch file which launches EMU8.EXE (does not work with USB).

Assuming you have DOS 5 or higher add the following line to your config.sys:

```
device=c:\dos\ansi.sys
```

To exit press control-Z twice. While in EMU8 you can engage the printer with control-P. Control-P again to turn printer off. If you ever need to type control-C to the controller then use control-X instead. Control-C is intercepted by the computer, which aborts EMU.

5. POWERING UP THE CONTROLLER

Mk5 controller

To power up the controller, connect the power cord at the rear and operate the power switch, which is integral with the power connector. You may have all other cables disconnected if you wish. However be sure to turn off the power before you connect any **rear** cable, especially the motor cable. When power is switched on the front TX light should flash which means it has sent the opening message to the computer, which you should see, in the communications window of ROBWIN. If the light flashes but nothing appears on the screen then this indicates a problem with the computer. Try clicking comms and select another COM port. If you have a USB-serial converter make sure the COM port selected matches the port shown in the device manager. Also make sure the baud rate is 19200.

The Mk5 controller utilizes the eZ80L92 microprocessor with Flash ROM and static RAM on the same PCB. Cold/warm/start selection is a front panel key switch. There is no memory protect switch as on previous models because the memory image is in flash ROM which is loaded to RAM when you power up (or press reset). When powering up for the first time select COLD start before you switch on. The message on screen should include the words COLD START.



Front panel designations:

Fail: indicates power supply problem e.g. low mains voltage. When power is turned on it stays lit until power supply is secure. Also lights when reset is pressed.

OK: opposite of fail, indicates good power supply.

TX: lights when serial data is passing from controller to computer

RX: lights when serial data is passing from computer to controller

STOP: stops robot motion (provided CPU is in control – see software manual)

RESET: resets CPU, DSP and other logic.

TEACH: teach pad input

COLD/WARM/AUTO switch – selects start-up mode when power is turned on or reset is pressed. (see section 7)

RS232 – connects to computer.

6. PREPARING FOR USE

Select cold start with the front panel key switch and switch on power. You should see a herald, including the words 'COLD START'.

Now enter the command (in caps)

ROBOFORTH

All joint positions are expressed as coordinates relative to the HOME position of the arm. Teaching the robot is a process of moving the arm by some means to the required position and recording the coordinates of that position which are either expressed as or related to joint positions. At the simplest level this is repeated to build up a list of positions. When replayed the arm moves from one position to the next in turn. (This is called point-to-point programming.)

If the power has been off then any program saved in an earlier session will not run in the same way unless exactly the same home position is first established. The home position for an R19 is with the waist such that the arm faces front, which is the side of the base away from the connectors. The Cartesian position of the HOME position is **typically** X=0.Y=150.0mm measured from the waist centerline to the hand pivot and Z=100.0 from bench surface to hand flange. The procedure for setting the robot to home position is as follows:

1. Use the teach box to drive the arm to approximately this position.
2. Exit teach mode with the escape key.
3. Enter the command CALIBRATE which will automatically set each robot joint to an exact number of steps away from the home position using the proximity detectors on the arm.
4. The command HOME will then drive the robot from this known position to the home position, which has each joint at zero count.

In order to move the robot its motors must be energized and the controller initialized for use. To do this enter START then the return key.

START

Among other things, START zeros all the variables, which track motor coordinates, initializes the DSP and the motor drive circuits and interface adapters and sets the current position as the home position.

7. GETTING STARTED

WARNING

**Before trying any of the following commands be sure to
KEEP OUT OF THE ROBOT ENVELOPE**

Note: **ALL FORTH and ROBOFORTH COMMANDS ARE IN UPPER CASE.**

Assuming ROBWIN is loaded and running:

1. Press caps lock and you should now be able to type ROBOFORTH commands into the communications window.

2. Type

ROBOFORTH <enter>

(if the key was set to 'cold')

3. Click Project, New/open then the full path name of your first project .RUN file, for example click to your c:\robot sub-directory and enter e.g.

test1.run

Click 'save'

You should now see three more windows appear. Re-select the communications window.

In the communications window type
START and press enter.

A herald will appear announcing ROBOFORTH and it's version.

Even though you have not yet calibrated the arm you can check out the axes with the teach pad.

To start moving the arm enter:-

TEACH

(or click the T button)

With this method pressing a key on the teach box moves the arm. Since you might let go of the key at any time and expect the robot to stop it is not possible to accelerate to high speed. Moreover a slow speed is more desirable to achieve precision, and the teach speed is determined by the value of CREEP-FACTOR, which is requested after you enter TEACH. At this stage just hit the return key.

After entering TEACH you are now in "TEACH mode". To move the arm first select the joint to move, J1 for waist, J2 for lift, J3 for extend, J4 for hand or wrist pitch, J5 for track or wrist roll. On selecting a joint the terminal/computer will beep. Then press either + or - for motion in a positive or negative direction. To test the gripper press the key marked 'GRIP', then to close the gripper press the + key and to open the gripper press the - key. Do not try other keys for the moment. Use TEACH mode to test all the joints and finally drive the robot to an approximate home position. Exit TEACH mode by pressing the escape (ESC) key on the terminal.

7. continued

Next the robot should be calibrated. Before trying the CALIBRATE feature check as many of the five proximity detectors as you can as follows:

First un-power the arm with

DE-ENERGISE or DE-ENERGIZE

Next display the sensors with:

PP

A row of 1s will appear on the screen thus:

11111111

This is a binary representation of the sensor input port. Hold a steel item against the waist sensor (which is visible just under the skirt) and the least significant digit should change to zero

11111110

The next digit is the lift sensor,

11111101

Next the extend sensor, next the hand sensor then wrist twist sensor. Only the waist sensor is accessible on the R19 but the other sensors can be checked by moving the joints by hand - move shoulder negative and move elbow positive. Press ESC to exit PP function then type

ENERGISE or ENERGIZE

Use TEACH mode again to set an approximate home position then press escape (ESC key). If the proximity detectors checked out OK then enter:

CALIBRATE

which drives all the joints to the proximity detectors and corrects the motor and encoder counts

HOME

drives the whole arm to the calibrated HOME position.

8. CONTROLLER SETTINGS

Changing default values

All the robot parameters revert to their original values when the controller is powered up or the reset is pressed. To make these values permanent you need to write them to flash ROM with the command

PSAVE

Be very sure you have not made a mistake before you use this command because if the flash ROM is corrupted it is very difficult to recover (see below).

FLASH ROM

Cold start mode

When power is switched on, or the reset button is pressed all RAM contents are refreshed from flash ROM. All the user programming, whether entered in immediate mode or using ROBWIN will be lost.

After you see the herald and the words 'cold start' enter

ROBOFORTH

Warm start mode

If power goes off/on or the reset button is pressed all RAM contents are refreshed from flash ROM including the user program area. Therefore your user program will be overwritten with any older program previously saved. To ensure that the new program is reloaded after a power-up or reset type the command

USAVE

Or click USAVE in ROBWIN.

If you forget to do this and accidentally lose power or press reset (or are forced to press reset because of a bug) then in ROBWIN save the project and re-open it.

Reload ROBOFORTH

If you corrupt ROBOFORTH and have done a PSAVE (thereby saving the error to flash ROM) you can reload ROBOFORTH as follows:

1. Select cold start and press reset.
2. Select file – download binary. Change parameters to start 4000, length 5E00 (bank should be 0)
3. Choose the backup file supplied with your robot e.g. R17C123.RAM You will see a blue progress bar.
4. When finished downloading enter ROBOFORTH
5. Enter PSAVE to reload the flash ROM.

9. ROBOT PARAMETERS

WARNING – there should be no reason to alter these constants unless some change has been made to the robot.

These parameters are particular to your robot, sometimes called a 'signature'. They are embedded into the ROBOFORTH, which is in protected memory.

RAM memory is loaded from flash ROM on each power-up or reset. If you change something you will need to update the flash ROM so test thoroughly before you do this.

If you are supplied with a new version of ROBOFORTH you will need to transfer the parameters to a disk file, load the new ROBOFORTH as described above then overlay the parameters file.

To save the parameters (signature)

1. Click file – save binary. Change parameters to start 9C00, length 100 (bank should be 0).
2. Save as e.g. R19D123.SIG – this is the serial number of the robot. The actual filename will be R19D123.SIG.ram
3. Enter PSAVE to save to the flash ROM.

To reload (overlay) the parameters.

1. Click file – load binary. Change parameters to start 9C00, length 100 (bank should be 0).
2. Choose file name you used to save above.
3. When loaded enter PSAVE to save the new ROBOFORTH and the overlaid parameters to flash ROM.

10 CALIBRATION

When the robot calibrates it seeks out proximity detectors on each axis and corrects the counts to values seen in the array LIMITS which you can view with VIEW LIMITS

You can, if absolutely necessary, change these values by directly addressing the element in the array, for example to change the value for the waist enter

(new value) LIMITS ! for the waist (that last character is the exclamation mark and it means 'store the value')

(new value) LIMITS 2 + ! for the lift axis

(new value) LIMITS 4 + ! for the extend

(new value) LIMITS 6 + ! for the hand

Next time you power up or press reset these value will revert to the original.

The accuracy of these figures affects the home position, and is particularly important in Cartesian transformations i.e. calculations of joint positions from Cartesian coordinates. If you wish to change these figures, for example if you reset or replaced a proximity detector, then the values in LIMITS can be changed as described above and under 'calibration' in the ROBOFORTH II manual.

GEAR RATIOS

The following constants are the numbers of motor half steps for 90 degrees of joint movement:-

Joint: WAIST LIFT EXTEND WRIST(yaw)

Constant: B-RATIO L-RATIO E-RATIO W-RATIO

To print the current value enter

B-RATIO. (that last character is a full stop or dot and it means print)

Or L-RATIO. for the lift etc.

ENERGIZING CURRENT

Although the high power motors will accept 4.7 amps we energize at less for two reasons:- (1) At low speeds the torque at the final drive can be very high so the reduced current reduces this torque for safety. (2) At a certain low speeds the rotor of a stepping motor can resonate resulting in vibration. This effect is eliminated by reducing the current. This also reduces low speed torque, which can be damaging when mistakes are made.

IDEAL GECKO 203V MOTOR DRIVE CURRENT SETTINGS. RESISTOR VALS

AXIS NO.	JOINT NAME	LOGIC CHAN.	AMPS	RESISTOR VALUE	MICRO-STEP SETTINGS	VALUE OF MICROS
1	WAIST	0	3.0	36k	10	4
2	LIFT	1	3.0	36k	10	4
3	EXTEND	2	2.5	27k	10	4
4	HAND	3	1.6	15k	10	4
5	TRACK	4	3.0	36k	10	4

11. CONNECTIONS-R19

Connections to the rear panel are identical with the controller as follows:-

	Robot Motor Drives (Bayonet)		Sensor (datum) inputs (25way D)
A	motor 1 coil 1	1	Sensor 1 (PB 0)
B	motor 1 coil 1	2	Sensor 2 (PB 1)
C	motor 1 coil 2	3	Sensor 3 (PB 2)
D	motor 1 coil 2		Sensor 4 (PB 3)
E	motor 2 coil 1	5	
F	motor 2 coil 1	6	encoder 1 up
G	motor 2 coil 2	7	encoder 1 down
H	motor 2 coil 2	8	encoder 2 up
J	motor 3 coil 1	9	encoder 2 down
K	motor 3 coil 1	10	encoder 3 up
L	motor 3 coil 2	11	encoder 3 down
M	motor 3 coil 2	12	encoder 4 up
N	motor 4 coil 1	13	encoder 4 down
P	motor 4 coil 1	14	
R	motor 4 coil 2	15	
S	motor 4 coil 2		
T	motor 5 coil 1	17	digital 0volts (sensors)
U	motor 5 coil 1	18	15-20v for sensors
V	motor 5 coil 2	19	dig. 0v (encoders) ground to robot
W	motor 5 coil 2	20	+5v for encoders
X	motor 6 coil 1	21	
Y	motor 6 coil 1	22	
Z	motor 6 coil 2	23	
a	motor 6 coil 2	24	
b	electric	25	
c	gripper		

RISK ASSESSMENT

This form must be completed by a competent Assessor for any procedure using the robot system **before** an attempt is made at the procedure by any worker or visitor.

For further information on hazards and risks please refer to the section SAFETY IS YOUR RESPONSIBILITY on page 5 of this manual.

Name and Status of the Assessor:

Date:

Activity being assessed:

Known or expected hazards associated with the activity:

The risk of injury and its severity likely to arise from these hazards:

Who is at risk?

Measure to be taken to reduce the level of risk:

Training prerequisites:

Level of risk remaining:

Emergency action:

References if any:

Signature of Assessor

Revision date