



NASA – Goddard Space Flight Center



NATIONAL AERONAUTICS
AND SPACE ADMINISTRATION

Mirror Automated Installation Device (MAID)

Edwin Lopez



R17 Design

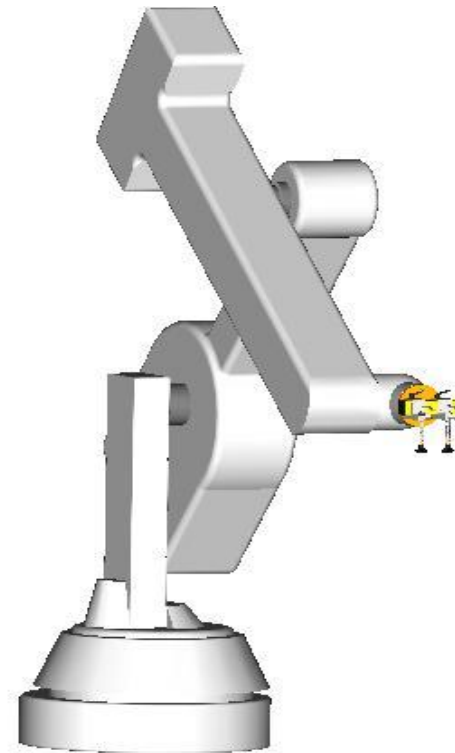
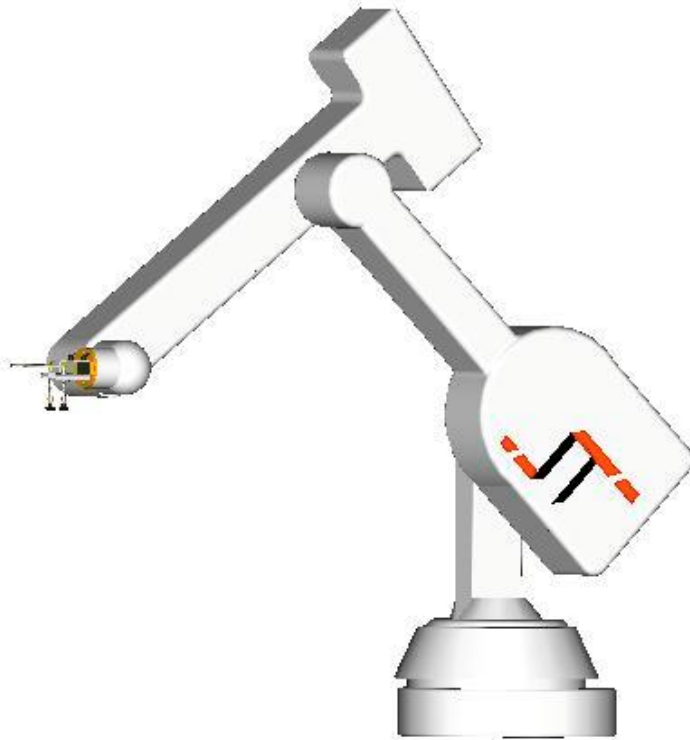



R17 Vacuum Device

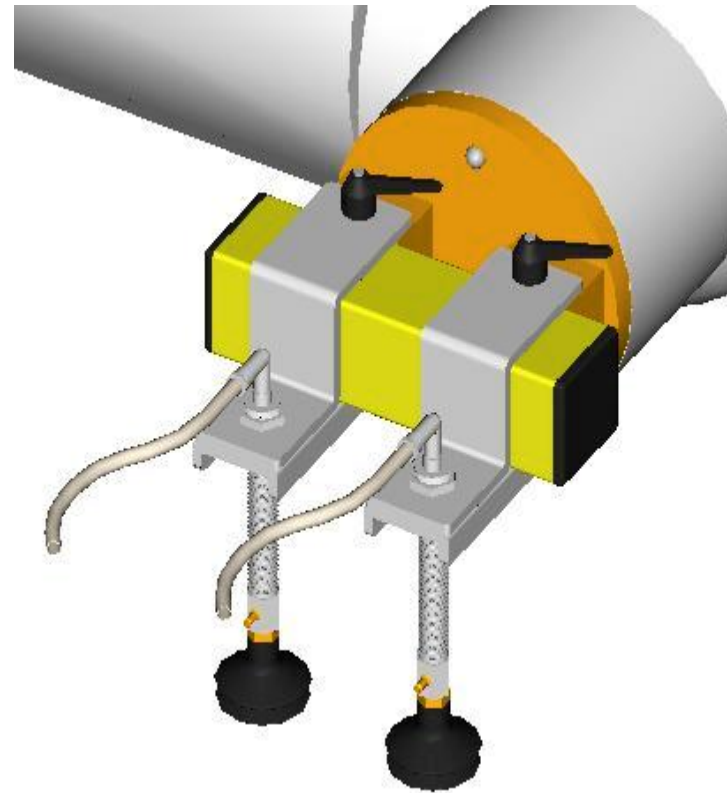
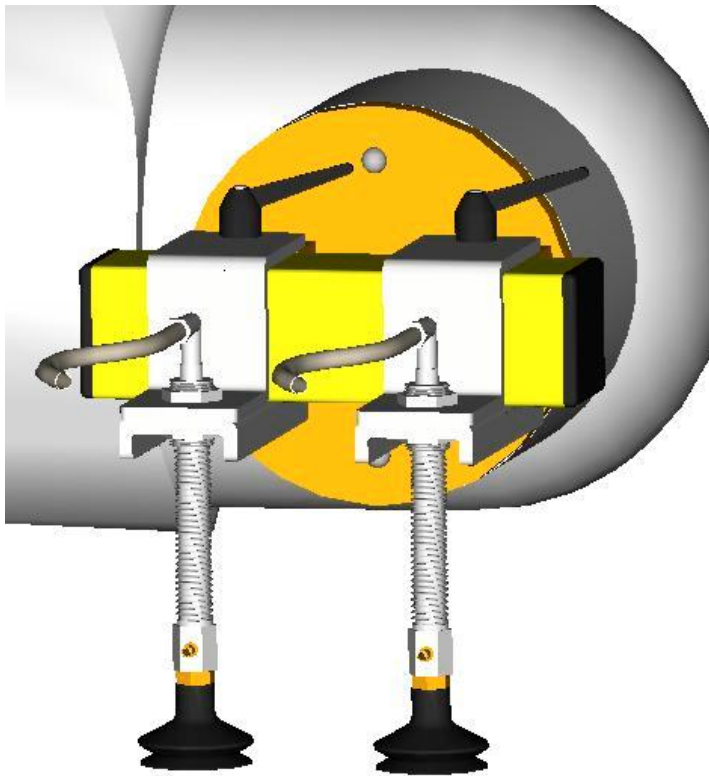



R17 Features

Features

Long reach articulated format, 5 axes.

Fully enclosed, space thru robot for user's wiring, etc.

Simple teach pad

Input/output interfacing

Non-volatile memory

Complete with controller, manuals, software, cables, etc. Ready to go

Optional track

Optional hazardous area preparation

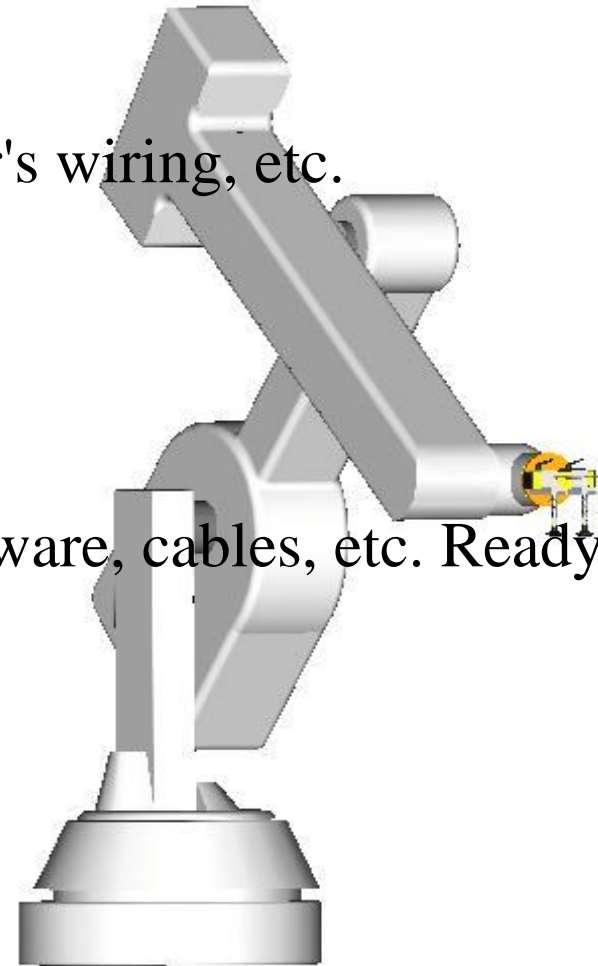



Rotary Axis

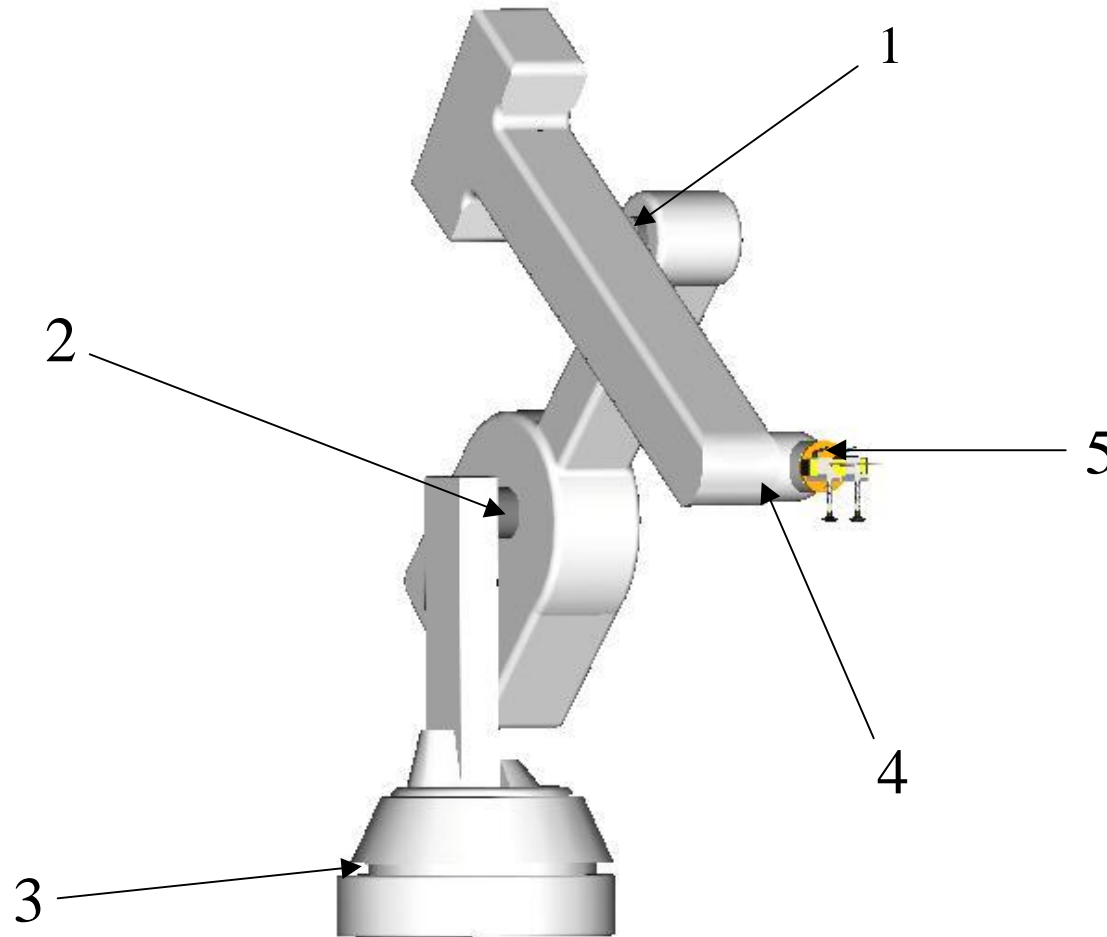



Rotation Angles Tolerances

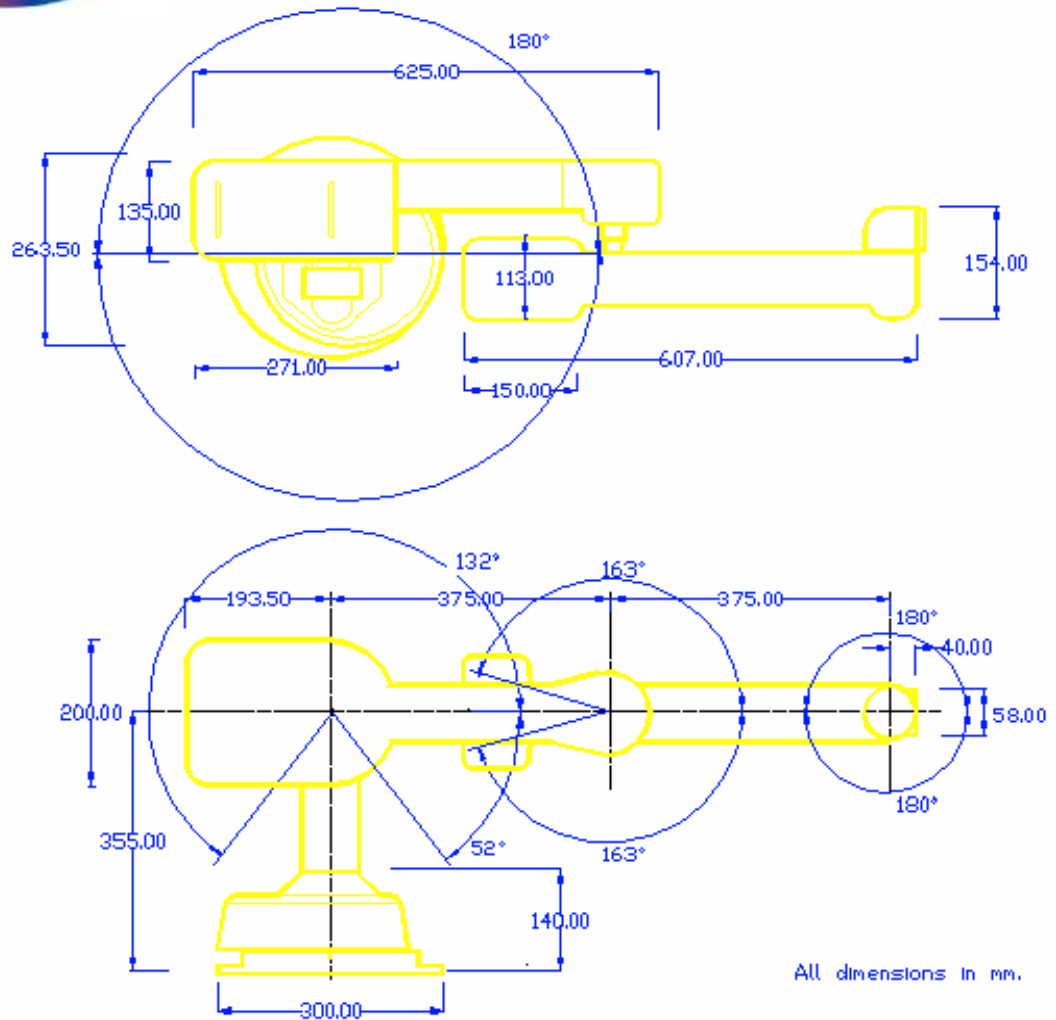



R17 Specs

Specifications	
Drives:	High power micro-stepped stepping motors, incremental encoder feedback
Reach:	750mm/30ins
Payload:	4Kg/8.8 lbs at flange (repeatability figures degrade).
Speed (standard):	Shoulder 100 deg/sec, Elbow 180deg/sec, Waist 120 deg/sec. (around 750mm/30ins per sec per joint, 2500mm/sec multi-joint)
Speed (turbo):	Shoulder 150 deg/sec, Elbow 270deg/sec, Waist 180 deg/sec. (around 4000mm/sec multi-joint)
Max torque for hand:	Pitch: 8 Nm Roll: 10 Nm
Repeatability:	+/-0.2mm
Acceleration:	2-3G
Weight:	22Kg/48lbs (robot only)
Power:	110/240v ac 420VA (standard controller)
MTBF:	10,000 hours

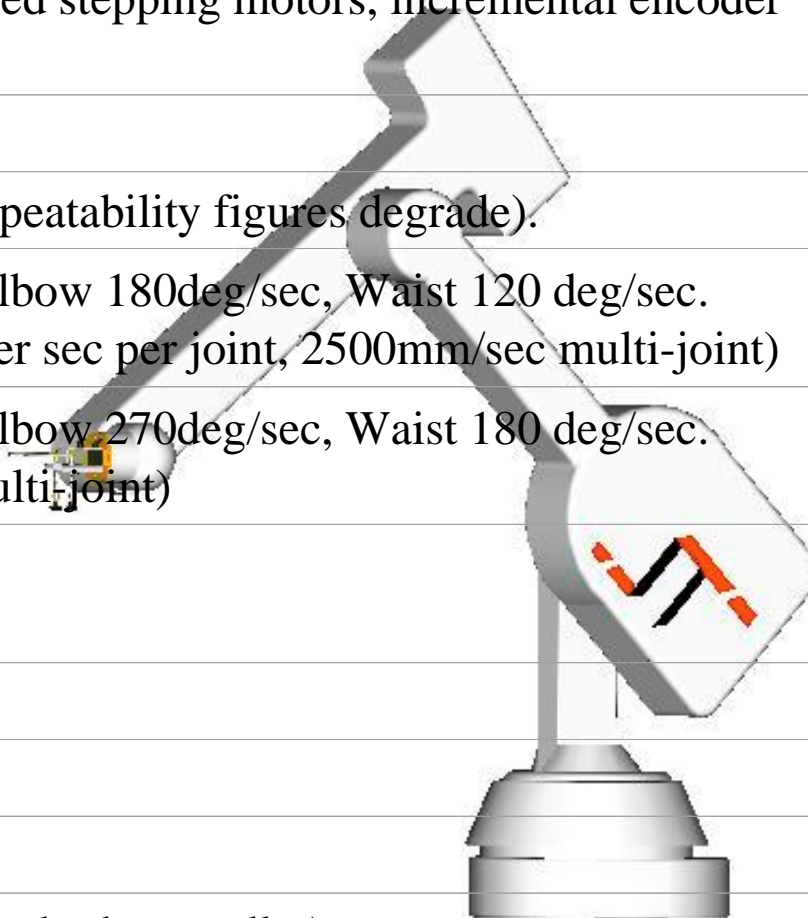



Mounting Plate Interface

The screws keep the mounting plate in place.

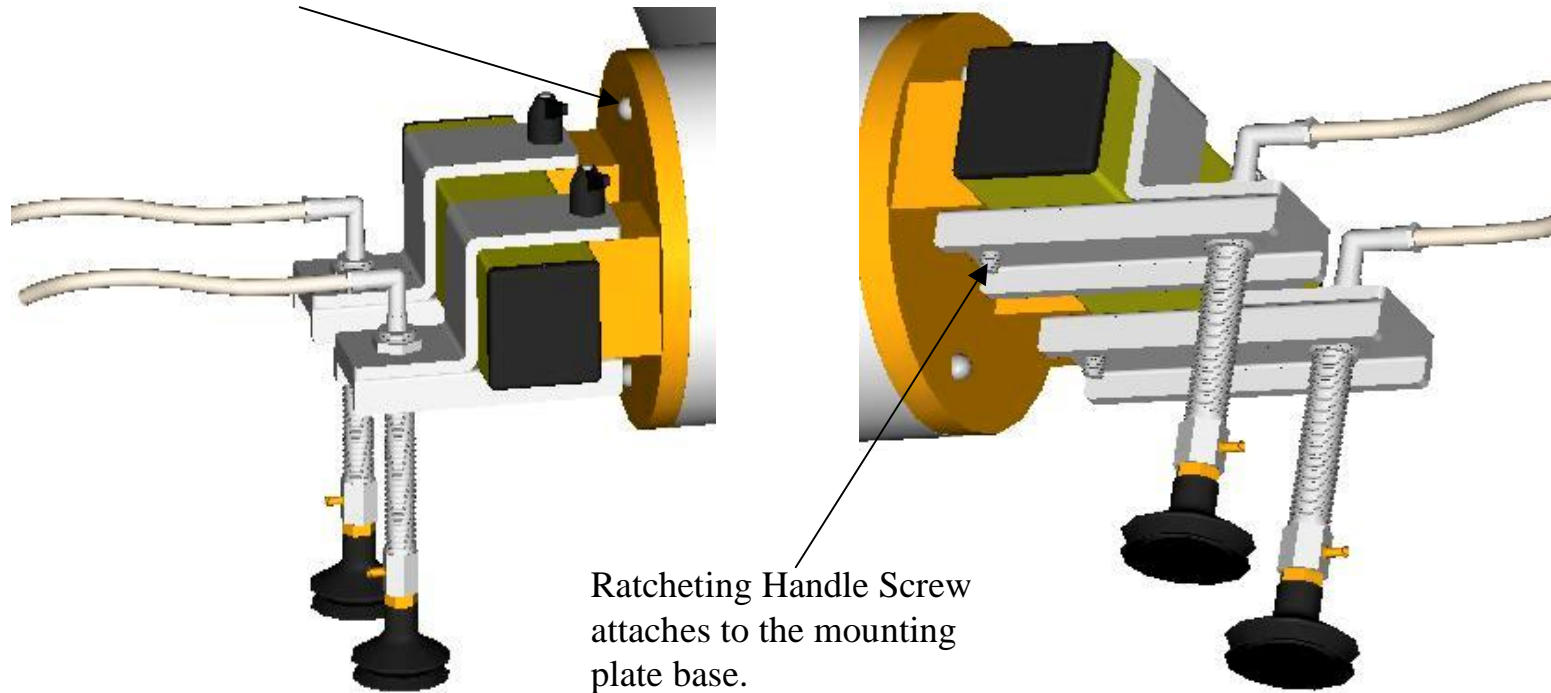



Vacuum Lifting Device

Features:

- Compact - only the size of a fitting
- Economical - no moving parts to break down
- Simple Mounting and Construction
- Low Air Consumption
- Lightweight yet Rugged
- Soft-Touch pick up for fragile loads

Can be mounted right to the suction cup for millisecond attach-and-release packaging applications

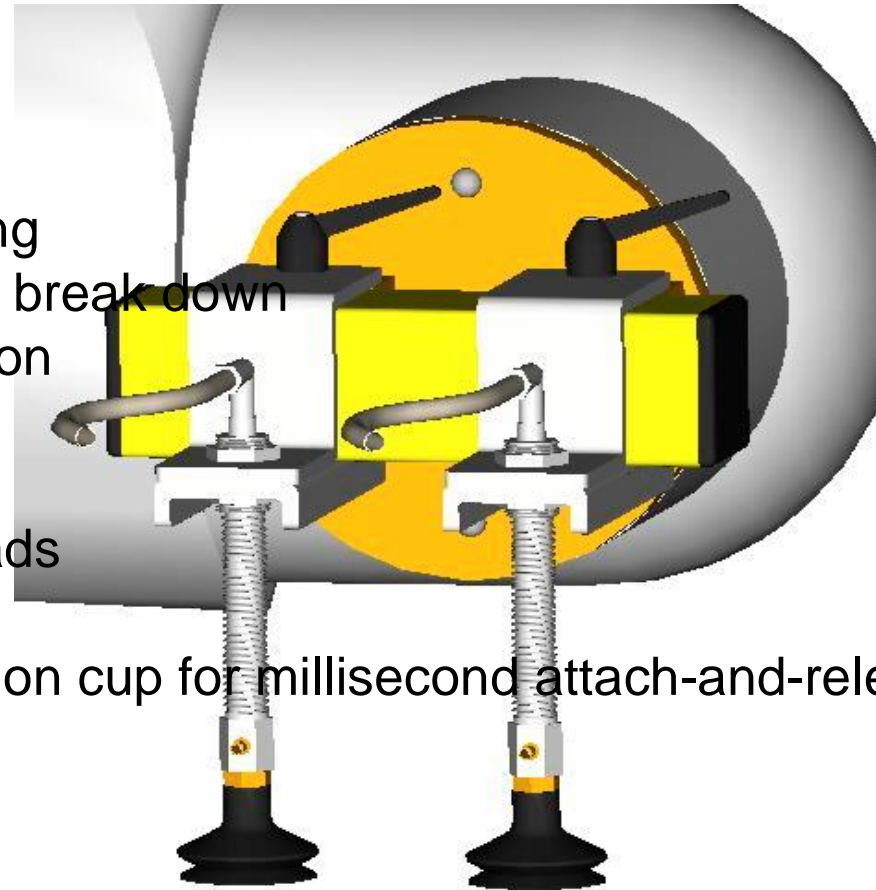



How VR Vacuum Pumps Work

