

R12 service manual rev 2010-07-14

SERVICE MANUAL

Contents:

Diagnosing errors with software
Backlash diagnosis
Chain adjustment
Sensor/encoder diagnosis
Sensor adjustment

How to

Encoder replacement
Hand sensor replacement

Diagnosing Mechanical Errors using software

The controller moves the motors by a software generated count. The encoders feed back into hardware counters which are compared to the motor counts by the CPU.

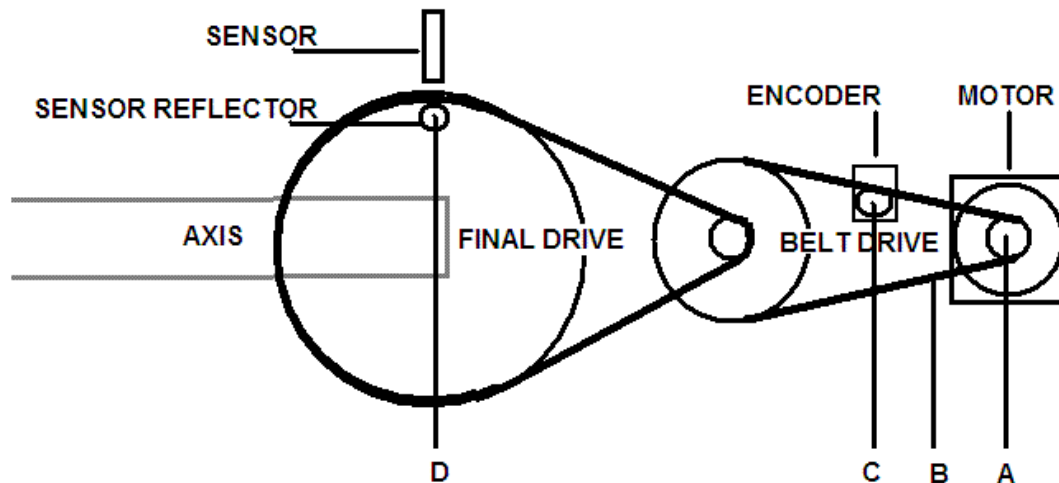

Waist drive chain

Above is a simplified diagram of the drive train for the waist drive.

A – motor drive pulley. If this is loose you should get an encoder mismatch (providing the error is more than the threshold in ENCTOLS)

Since the axis has now not synchronized to the motor you will also see an error reported after CALIBRATE

B – drive belt. Occasionally these can stretch in one place. If so this will produce a calibrate error though not necessarily an encoder error. Use the teach pad to drive one complete rev and watch the belt teeth run over the pulleys. A stretched part will cause the belt to lift or jump.

C – encoder and pulley. A problem here will cause an encoder error but a subsequent CALIBRATE will not show an error because there is no loss of linkage between motor and final drive.

There is no torque on the encoder so a loose pulley is unlikely to be a culprit. Check that the pulley is in loose mesh with the belt. If under high torque conditions the belt is able to go slack and move away from the pulley you may have to move the pulley closer to the belt.

At HOME enter ENCTEST to continuously display the encoders. They should all be zero except the suspect one. Force the encoder one tooth one way or the other to see if it corrects the error. If the error is one or more exact teeth then mesh is the problem.

Also check that the encoder itself is not loose and able to move – tighten the fixing nut if necessary.

D – final calibration sensor. If you are getting positional errors which are confirmed by CALIBRATE yet you had no encoder error then the problem must

be in the drive **after** the first belt. Check to see if the dual pulley is able to move i.e. if one of its pulleys can move relative to the other. You would need to have the robot energized and use hand force.

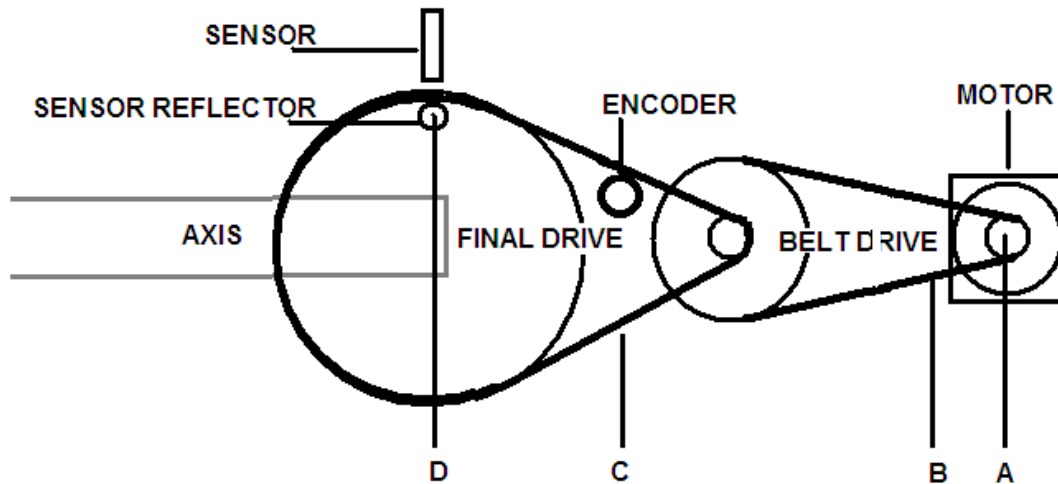

Arm drive chain

Above is a simplified diagram of the drive train for the arm drives.

A – motor drive pulley. If this is loose you should get an encoder mismatch (providing the error is more than the threshold in ENCTOLS)

Since the axis has now not synchronized to the motor you will also see an error reported after CALIBRATE

B – drive belt. Occasionally these can stretch in one place. If so this will produce a calibrate error though not necessarily an encoder error. Use the teach pad to drive one complete rev and watch the belt teeth run over the pulleys. A stretched part will cause the belt to lift or jump.

C – encoder and pulley. A problem here will cause an encoder error but a subsequent CALIBRATE will not show an error because there is no loss of linkage between motor and final drive.

There is no torque on the encoder so a loose pulley is unlikely to be a culprit.

Check that the pulley is in loose mesh with the belt. If under high torque conditions the belt is able to go slack and move away from the pulley you may have to move the pulley closer to the belt.

At HOME enter ENCTEST to continuously display the encoders. They should all be zero except the suspect one. Force the encoder one tooth one way or the other to see if it corrects the error. If the error is one or more exact teeth then mesh is the problem.

Also check that the encoder itself is not loose and able to move – tighten the fixing nut if necessary.

D – final calibration sensor. If you are getting positional errors which are confirmed by CALIBRATE yet you had no encoder error then the problem must be in the final belt.

“ENCODER-STEPPER MISMATCH”

This error can mean one of the following, in order of probability:

The robot in a collision

The robot was going too fast and a motor came out of synchronism

One of the drive belts is damaged

Something wrong with the motor drive e.g. loose pulley

Something wrong with the encoder

It is also worth noting that the encoders are very sensitive and are subject to the non-linearity of the final toothed belts. Therefore the encoder might be working correctly but simply exceeding the tolerance set in ENCTOLS.

To find out which run the robot open loop with the command
ENCOFF

Then do CALIBRATE HOME CALIBRATE and see if the errors reported are in the same range as reported by the encoders. If not then the encoder error is mis-reported. This does not mean there is a problem with the encoder. If the encoder errors are less than 50 then you may need to do nothing more than increase the corresponding value in ENCTOLS.

To increase the tolerance for the waist encoder enter
(new value) ENCTOLS !

To increase the tolerance for the shoulder encoder enter
(new value) ENCTOLS 2+ !

To increase the tolerance for the elbow encoder enter
(new value) ENCTOLS 4 + !

To increase the tolerance for the hand and wrist encoders enter
(new value) ENCTOLS 6 + !

Drive train health check

Step 1

Enter
START
CALIBRATE
ENCOFF
HOME
CALIBRATE

What errors are reported from CALIBRATE? If there is a substantial error on an axis then it means there is a problem mechanically with that axis, for example: broken belt, loose pulley on a motor or other shaft etc.

If there are no substantial errors (less than, say 5 counts) then

Step 2

Enter:
ENCOFF
HOME
START
CALIBRATE
ENCOFF
HOME
WHERE

After this sequence of operations the counts under WHERE should show all the motor counts as zero. The second line displays the actual encoders, ignore these. The third line displays the converted encoder count i.e. what the motor should be according to the encoders. Ideally these should also be zero or else just a few counts out. Any substantial error means there is a fault with the encoder.

See also SETUP diagnostics later.

Diagnosing mismatch in an application

It might be that it takes a while for ENCODER STEPPER MISMATCH to appear. As soon as ENCODER STEPPER MISMATCH comes up immediately type
ENCOFF
HOME

If there are any errors on the bottom line make a note of size and axis

Then enter
CALIBRATE

If there are any errors reported then compare them to the numbers in step 2. If they are similar and same axis then the problem is the motor.

Possible problems:

Slipping pulley

Pulley rubbing on motor or on casing or on another pulley.

Damaged belt.

If the CALIBRATE errors are zero then the motor and transmission were fine and the error lies with the encoders.

Possible problems:

Bad mesh of encoder pulley into the belt.

Faulty encoder (rare)

Do the encoders work?

Put the robot at approx Home position and enter

START DE-ENERGIZE ENCTEST <enter>

The count for each axis is displayed as you move each axis by hand.

Press <esc> key to exit.

Do the sensors work?

Put the robot at approx Home position and enter

START DE-ENERGIZE PP <enter>

You will see a line of 8 digits e.g.

11111110

These represent the inputs to PB and the 5 least significant digits (5 furthest right) are the 5 sensors. Normally the waist will be a zero. It has a NPN sensor that normally sees a metal pulley and the sense point is a hole in the pulley.

When this hole lines up with the sensor it changes to 1

11111111

The other sensors are PNP and also sense holes in pulleys. They are therefore a 1 and change to 0 when the hole lines up with a sensor, e.g. for shoulder

11111110 changes to 11111100

Sensor adjustments.

Waist Sensor adjustment

You will need to remove the base covers to reveal the sensor. Take care as these covers are fairly fragile.

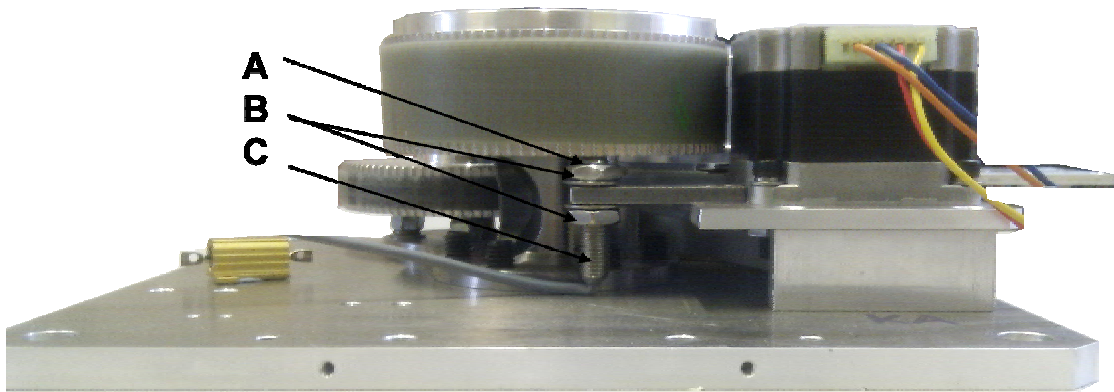

The waist sensor is shown above, A-C. At the bottom end there is normally a small amber LED.

This sensor senses the aluminium pulley just above it. When sensing the LED will be brighter. There is a notch cut into the edge of the pulley. When that notch lines up with the sensor the aluminum is no longer sensed.

Enter DE-ENERGISE to remove motor power then
PP

you should see
11111110

Rotate the waist (without power) slowly until the notch reaches the sensor; this changes to
11111111

The LED will also get dimmer.

To adjust the sensor:

1 Rotate the pulley so the notch is not in line with the sensor.

2 Unlock the two nuts at B (13mm wrench).

3 Slowly unscrew the sensor (which is screwed into the plate) until the display changes to 11111111 then screw back up again until you see 11111110

4 Rotate the pulley slowly until the notch is in line and check that it changes to 11111111

Shoulder and Elbow Sensor adjustment

The shoulder and elbow sensors sense a steel flange for most of the time. The PNP sensor pulls up showing a '1'. When the hole lines up with the sensor it changes to '0'. The sensor is a flat 4mm square section device held in place by a strap and it has a thin plastic shim behind it. It may be necessary to add additional shim or replace with thinner. See diagram below. The sensor is shown **dark red** and the shim is shown **light red**. The sensor is held in place with a strap (shown gray) and 2 screws.

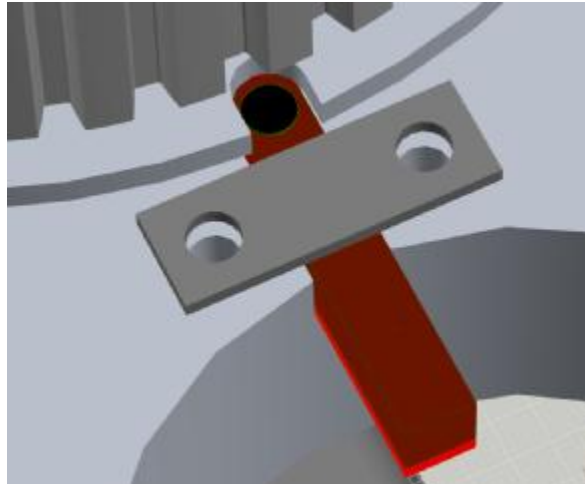

fig.1 Shoulder and elbow sensor

The sensor is waiting for the cut-out in the flange to come round to the sensor. Enter DE-ENERGIZE so you can move the robot by hand and enter PP to display the sensor conditions (press escape to exit PP). You should see

11111110

Normally the sensor senses the metal and shows a 1 in the position second from the right. As you move the shoulder hole over the sensor the display changes to 11111100. It should return immediately the hole has passed. The same applies to the elbow sensor:

11111010

Fig 2 below shows a gap between the sensor and the flange. This should be about 0.5mm.



Fig 2 shoulder sensor adjustment

Hand (L-hand) adjustment

The hand has 2 sensors, one for channel 4 (L-hand) and one for channel 5 (wrist). The L-hand sensor senses a *steel flange* for most of the time. The PNP sensor pulls up showing a '1'. When the hole lines up with the sensor it changes to '0'. The sensor is a flat 4mm square section device held in place by **two** set screws (see diagram below).

Wrist (5-axis version) or Yaw (6-axis version) adjustment

The wrist sensor senses the *aluminium* pulley most of the time. The pulley has a hole machined in it. The PNP sensor pulls up showing a '1'. When the hole lines up with the sensor it changes to '0'. The sensor is a flat 4mm square section device held in place by **two** set screws (see diagram below).

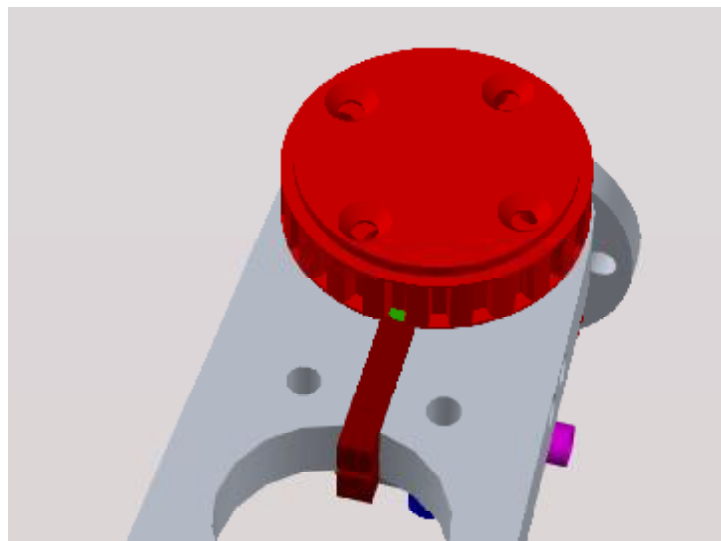

Fig 3 L-hand sensor showing alignment with the cut-out in the flange.

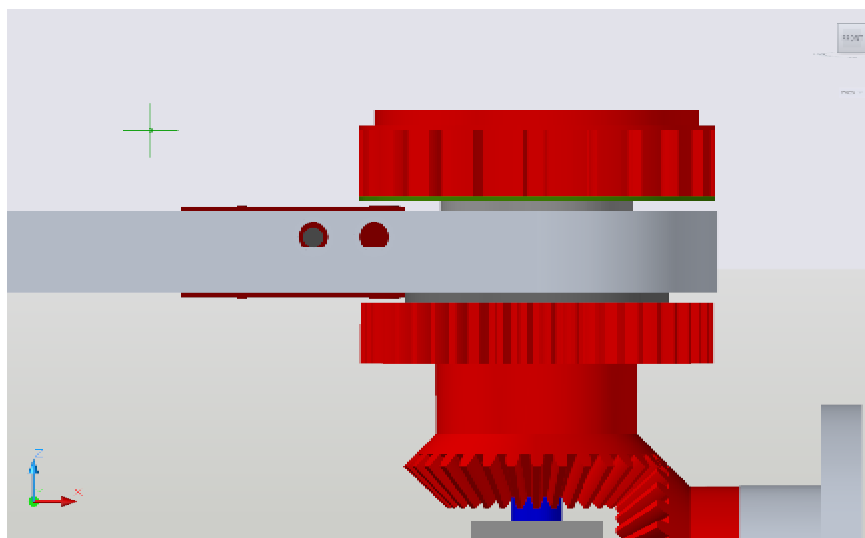

Fig 4 showing gap between the sensors and the pulleys.

The gap between the sensor and the pulley is critical. It should be about 0.5mm but is best adjusted using the system.

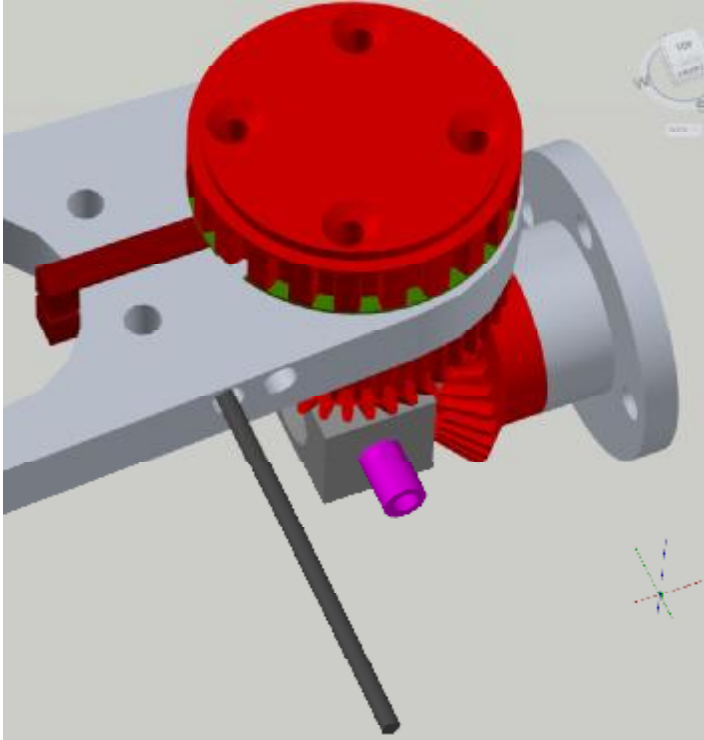

fig.5 L-hand sensor showing Allen key position.

Proceed as follows:

Enter

DE-ENERGIZE

So you can move the robot by hand.

Enter PP This should display

11111110

From **right to left** these are the states of waist, shoulder, elbow, L-hand, wrist.

To adjust the L-hand sensor slacken the set screws adjacent to it (they are offset from the center-line). Have the pulley so that the slot is not over the sensor. Move the sensor away from the pulley until that bit changes to 0

11110110

Then move it back carefully until it changes back to 1

11111110

Tighten one set screw a little.

Rotate the pulley so the slot goes over the sensor. The bit should go to 0

11110110

Tighten the other screw.

Do not over-tighten

To adjust the wrist (R-hand, 5th) sensor slacken the set screws adjacent to it (they are offset from the center-line). Have the pulley so that the hole is not over the sensor. Move the sensor away from the pulley until that bit changes to 0

11101110

Then move it back carefully until it changes back to 1

11111110

Tighten one set screw a little.

Rotate the pulley so the slot goes over the sensor. The bit should go to 0

11101110

Tighten the other screw.

Press escape to exit the PP function.

Sixth Axis sensor adjustment

IMPORTANT: do not back-drive the 6th axis wrist roll.

See diagram below:

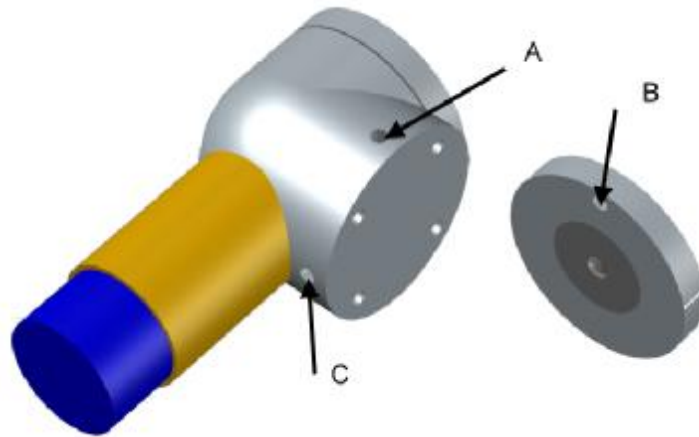

The diagram shows: left the complete assembly, right the mounting plate. Calibration works as follows: most of the time the sensor (mounted at C) is sensing the mounting plate and reads '1'. During CALIBRATE or DATUM the plate rotates until the hole B lines up with the sensor then it changes to '0'.

With the arm in HOME position enter PP. You should see

11111110

If you see

11011110

then the wrist roll is on the sensor. It should be possible to clear the sensor by moving the wrist roll motor with a command:

```
TELL WRIST 1000 MOVE
```

you should now see

11111110

If, no matter where you send the wrist you always see 11011110 then the wrist sensor is too far from the plate. Slacken the sensor set screw at A and push the sensor in using the wire at C until it contacts the plate. The PP should change to 11111110. Now pull the sensor back, estimating 0.5mm. The read should stay at 11111110. If it goes to 0 then push back in a little. Now test with

```
TELL WRIST DATUM
```

You may get a "too far message", repeat the command a few times until the sensor hole is reached. Of course if you have gone 360 degrees then you may need to check adjustment again. Be sure about adjustment before replacement of sensor.

Encoder check and replacement.

Refer to diagram below to locate the encoder.

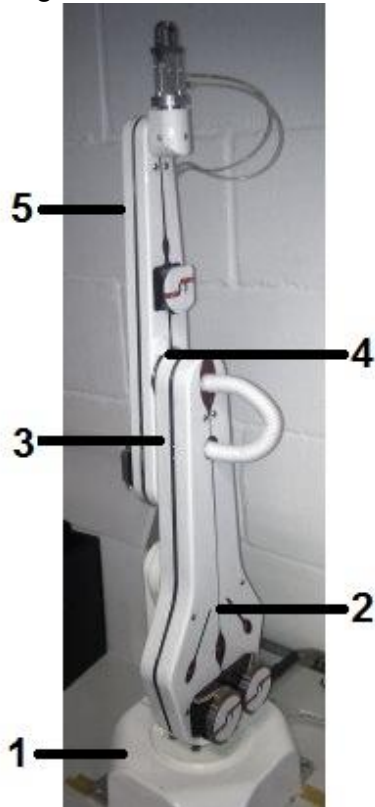

Channel 1 (waist) is a Bournes encoder.
Channels 2-5 are Avago encoders.

There is no encoder on the 6th axis.

Check/replace Avago encoder

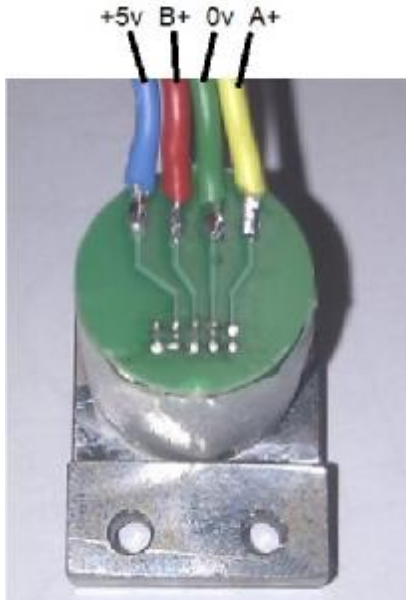

Note wire colors may vary.

First enter ENCTEST

And rotate the encoder by hand. If the counts go up and down as you rotate forward and backward then there is no fault.

If the count does not change then check there is a supply to the encoder. There should be 5 volts (approx) between the +5v and 0v wires. If not then check down the loom for a broken or damaged wire.

If the count goes up and down by 1 count only then this indicates one of the signals (A+ or B+) is missing but not both. Using a voltmeter, logic probe or oscilloscope check the A+ and B+ signals. As you rotate the encoder pulley these should change back and forth between about 5v and 0v. Not obvious with a voltmeter but should be discernible if you rotate very slowly. If both signals are present but there is no change in ENCTEST then there may be a broken or damaged wire in the loom.

If both signals are absent yet there is 5v power then you will need to replace the encoder.

Robot health check

Load the project "SETUP" (setup.run)

This loads a number of diagnostic and setting up commands.

You can check the calibration repeatability with the command

CTEST

This tests calibration at high and low speeds and reports the errors compared to the previous calibration. Ideally no error will exceed 10 counts.

You can check encoder repeatability with the command

ETEST

This reports the encoder errors compared to ideal at each of 1000 count movement. No error should exceed 50 for a healthy robot.